DSP-599zx

Audio Noise Reduction Filter

Features

Revision 1.1



Congratulations

You are reading about the most advanced digital signal processor available. Timewave Technology Inc. occasionally offers performance enhancing updates to its products. Updates and corrections to information and specifications will be made to this Features Manual when needed.

Copyright

© 1994, 1995, 1996 by Timewave Technology Inc. All rights reserved.
Printed in USA

Under the copyright laws, this manual can't be reproduced in any form without prior written permission from Timewave Technology Inc.

Timewave Technology Inc. strives to deliver the best product to our customers. As part of this goal, we are constantly trying to improve our products. Timewave Technology Inc., therefore, reserves the right to make changes to product specifications or documentation without prior notice.

This Features manual may contain errors, omissions or "typos." Please send your comments, suggestions and corrections:

Timewave Technology Inc.
2401 Pilot Knob Road
St. Paul, MN 55120 USA

dsp@timewave.com E-mail
<http://www.timewave.com> FAQ and Information

(612)452-5939 Voice
(612)452-4571 Fax

Controls

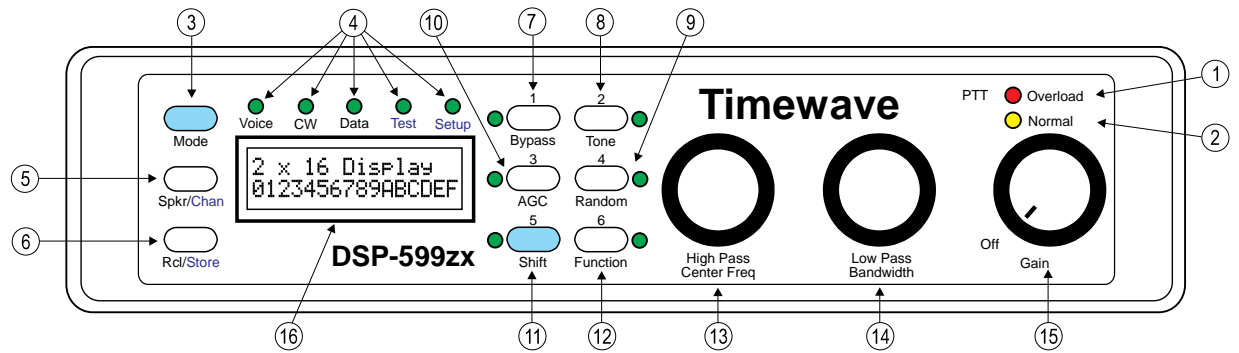

599-002

Front Panel

- 1. PTT/Overload LED**
 Red LED indicates a too high signal level into DSP-599zx from receiver. When PTT line from transceiver is connected, red LED on indicates PTT is activated.
- 2. Normal**
 Yellow LED indicates normal signal level into DSP-599zx.
- 3. Mode switch**
 Press to change mode (Voice, CW, Data). Press **[Shift+Mode]** to switch to Setup and Test modes.
- 4. Voice, CW, Data, Test, and Setup LEDs.**
 Indicate the selected mode of the DSP-599zx.
- 5. Spkr/Chan switch**
 Press to toggle speaker on and off. Press **[Shift+Mode]** to switch from Channel A input to Channel B input.
- 6. Rcl/Store switch**
 To recall memory, press this key and then one of the switches labeled 1 to 6. To store current settings in a memory, press **[Shift+Rcl/Store]**, then one of the switches labeled 1 to 6.
- 7. Bypass Switch**
 Press to Bypass DSP filtering.
- 8. Tone Switch**
 Heterodyne elimination for Voice. Marker Tone for CW and Data. Press **[Shift+Tone]** to activate manually tuned notch filter.
- 9. Random switch**
 Used to turn on random noise reduction. Press **[Shift+Random]** to activate variable noise reduction.
- 10. AGC switch**
 AGC on.
- 11. Shift switch**
 This blue switch shifts the function of the next switch pressed to its function labeled in blue.
- 12. Function switch**
 This switch is used to enter into menus and other specialized functions.
- 13. High Pass/Center Freq Control**
 Tunes the high pass filter in the Voice mode. Tunes the bandpass filter center frequency in CW and Data mode. In most menu modes, this knob is rotated to see menu choices. Pressing the knob to selects the choice.
- 14. Low Pass/Bandwidth Control**
 Tunes the low pass filter in the Voice mode. Tunes the bandpass filter bandwidth for CW and Data mode. Pressing knob will turn off temporary settings.
- 15. Gain/Power On/Off**
 Turns power on and off, and volume control for speaker output.
- 16. LCD Display**
 Backlit 2x16 alphanumeric display of mode, control, and test settings and data.

Connectors

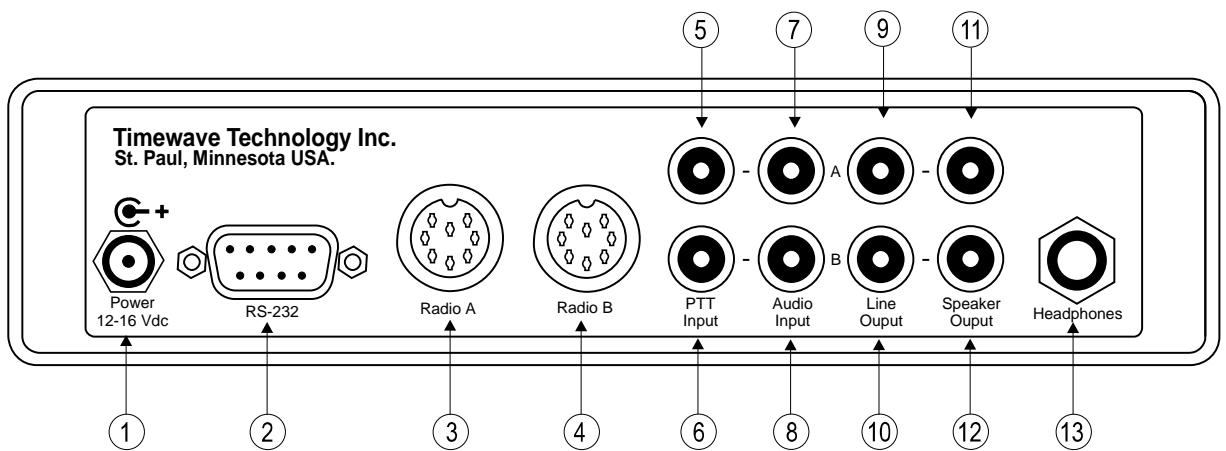

599-005

Back Panel

1. Power In

12-16 Volts DC Use 5.5 mm/2.1 mm matching plug, center positive.

2. RS-232

RS-232 compatible RTTY modem serial output for computer interface. DB-9F connector. Refer to chapter 2 for pin configuration.

3. Radio A

Alternative single 8 pin DIN connection for line out, audio in, PTT out, PTT in, aux. digital in. Also contains connections reserved for future options.

4. Radio B

Alternative single 8 pin DIN connection for line out, audio in, PTT out, PTT in, aux. digital in. Also contains connections reserved for future options.

5. PTT Input A

PTT line from transceiver A PTT output. RCA Phono connector.

6. PTT Input B

PTT line from transceiver B PTT output. RCA Phono connector.

7. Audio Input A

Audio input from radio speaker output - channel A. RCA Phono connector.

8. Audio Input B

Audio input from radio speaker output - channel B. RCA Phono connector.

9. Line Output A

Line level output to multimode data controller - channel A. Gain control doesn't vary this output. RCA Phono connector.

10. Line Output B

Line level output to multimode data controller - channel B. Gain control doesn't vary this output. RCA Phono connector.

11. Speaker Output A

4-8 ohm speaker output - channel A. RCA Phono connector.

12. Speaker Output B

4-8 ohm speaker output - channel B. RCA Phono connector.

13. Headphone Jack

Stereo headphone jack for 1/4" stereo plug.

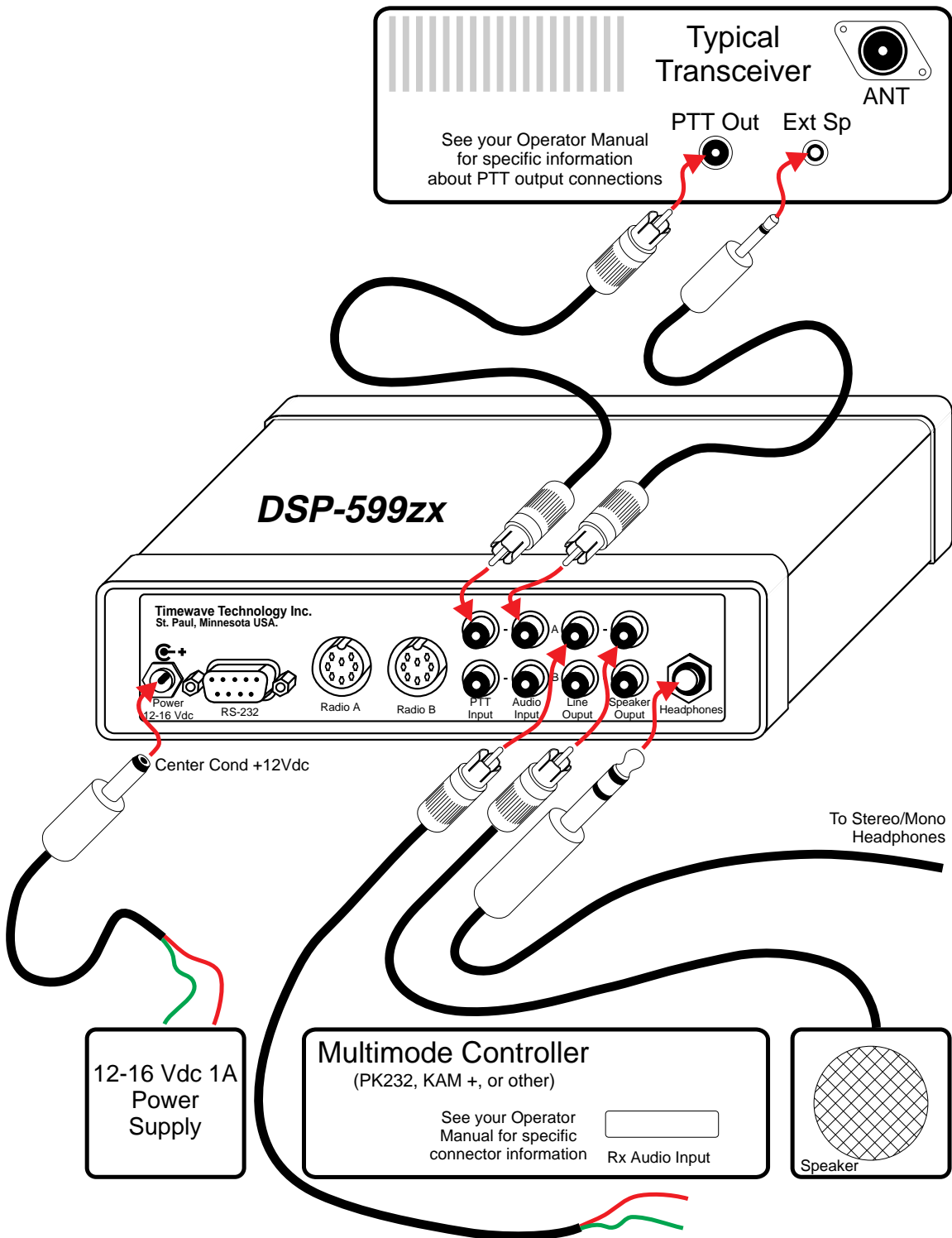

599-010

Consult the installation section of this manual for more information on cables and connections.

Voice Mode

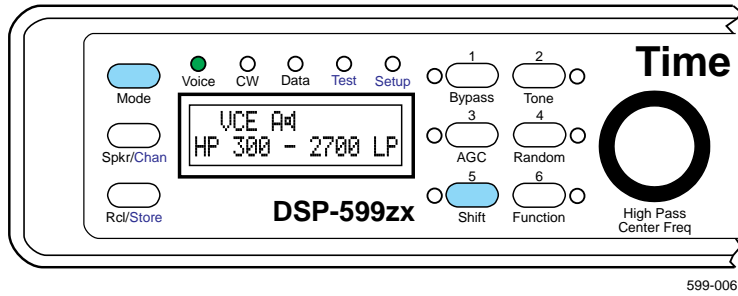

Typical display for Voice mode, 300 Hz to 2700 Hz filter, A channel active and speaker on.

CW Mode

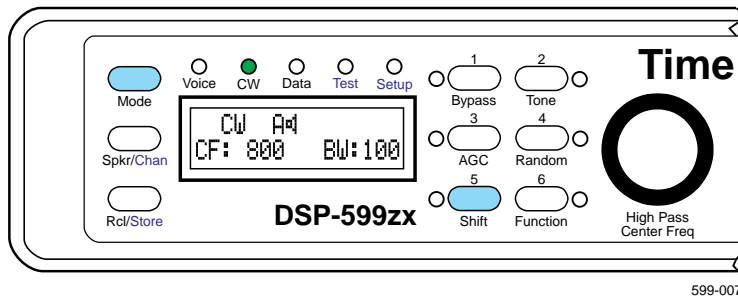

Typical display for CW mode, Center Frequency at 800 Hz and Bandwidth set to 100 Hz filter, A channel active and speaker on.

Data Mode

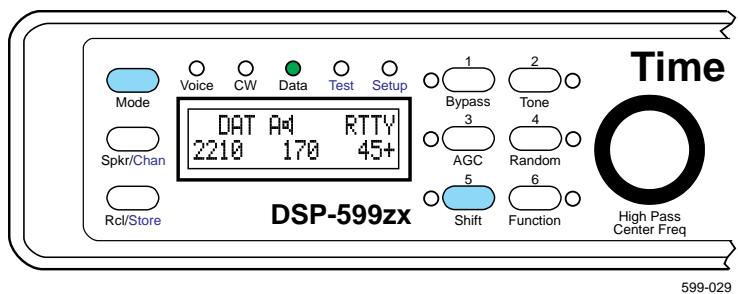

Typical display for RTTY Data mode. Center frequency at 2210 Hz, offset at 170 Hz and baud rate of 45. A channel active and speaker on.

DSP-599zx Introduction

The previous section includes a short summary of both the front panel controls and the rear panel connectors. Please see *DSP-599zx Specifications* at the rear of this document for detailed information on the capabilities of the DSP-599zx.

Digital Signal Processing

Digital Signal Processing (DSP) is a powerful and complex method of analyzing and modifying analog signals. Audio signals like speech or radio data are analog signals. The speech and data signals have fairly well known and predictable characteristics; however, these characteristics are quite complex. By converting the analog signal to a digital signal, a powerful digital signal processor with a special program can analyze the characteristics of the analog signal. The digital signal processor can then modify the digital signal to enhance desired characteristics and to remove undesirable characteristics such as noise. The processed signal is converted back to an analog signal and sent on to a speaker, headphone, or data controller. The result is a signal with less noise and/or fewer data errors. In amateur radio terms, DSP is capable of reducing or eliminating QRN (noise) and QRM (interference).

For a more detailed discussion of digital signal processing, consult the most recent *ARRL Handbook*.

DSP-599zx Overview

The DSP-599zx is an extraordinarily versatile digital signal processor designed for amateur and shortwave radio voice, data and CW operation. The DSP-599zx uses advanced digital signal processing technology to implement algorithms that perform five basic audio functions:

- Random noise reduction
- Adaptive multi-tone and manual notch filtering (Tone noise reduction)
- Bandpass/Highpass/Lowpass filtering
- Signal generation including FSK RTTY modulation
- Signal detection and measurement including RTTY demodulation

The DSP-599zx combines these five basic functions to reduce noise and interference and improve radio communication. The DSP-599zx hardware and software architecture allow easy field upgrade with new features and algorithms. The same hardware and software architecture also allow ergonomic mode oriented operation of the DSP-599zx. The LCD alpha-numeric display provides a clear view of operating settings when switching between operating modes. The quick-select push buttons and optical encoders for filter tuning allow instant mode change with total recall of last setting and memories. Front-panel selectable and adjustable inputs allow you to quickly setup and adjust your DSP-599zx to wipe out noise and QRM like never before!

Here are a few more highlights among the many other operating features of the DSP-599zx:

- Selectable Automatic Gain Control
- Configurable bypass control
- Two selectable input channels
- Two configurable output channels
- Six memories for instant recall of user-defined configurations
- Test instrument mode for analyzing signals and other equipment

Signal Flow

The DSP-599zx converts analog signals into digital signals before it routes and processes them. The digital signal processor also controls the front panel switches, encoders, LEDs, LCD display, and back panel inputs and outputs. This figure is a greatly simplified block diagram of the DSP-599zx.

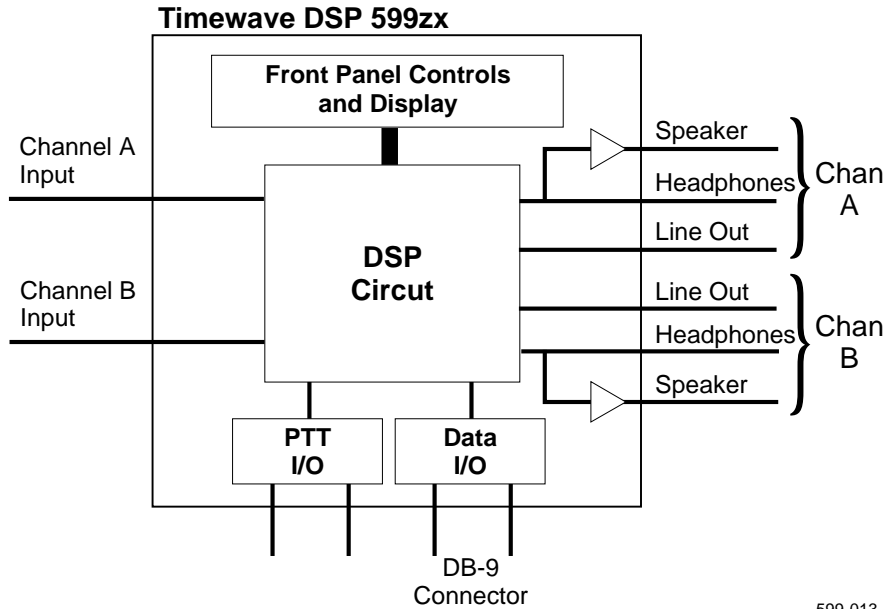

599-013

Features Common to All Modes

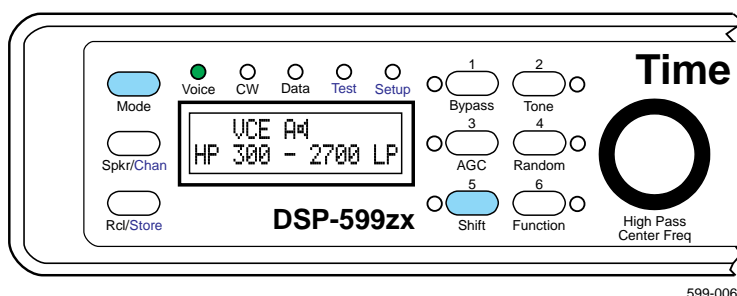

Random/Tone Noise Reduction

The noise reduction functions of the DSP-599zx operate by examining a characteristic of signals and noise called *correlation*, and dynamically filtering out the undesired signals and noise. The degree of correlation is relative. Random noise such as white noise or static is uncorrelated. Speech is moderately correlated. Repetitive or continuous noise such as a heterodyne is highly correlated. The DSP-599zx measures correlation and filters out signals and noise that are outside its correlation thresholds. The amount of noise reduction varies according to the correlation characteristics of the noise. Typical noise reduction ranges from 5 dB to 20 dB for random noise and up to 50 dB for heterodynes.

Adaptive Multi-tone and Manual Notch Filtering (Tone noise reduction)

The DSP-599zx has both an automatic notch filter and a manually tuned filter. The automatic notch filter is an adaptive multi-tone filter that can remove multiple tones simultaneously. The automatic multi-tone filter removes multiple heterodynes almost completely. The **[Center Freq]** encoder on the front panel tunes the manual notch filter. The manual notch filter is selectable and has a wide bandwidth filter for data signals and a narrow bandwidth filter for CW signals and heterodynes.

Dual Channel Operation

The DSP-599zx is a dual channel device with two sets of inputs and outputs. The DSP circuit completely processes the selected channel, while signals on the other channel pass through the DSP circuit without processing. Settings for each channel are retained when switching between channels.

The two input channels allow you to connect either two separate radios or a dual channel radio with two outputs to the DSP-599zx. You may configure each channel to completely different operating modes. Selecting the opposite channel returns the DSP-599zx to the previous settings on that channel.

This is very handy for two rig operations when setting one rig to monitor CW and the other to monitor voice.

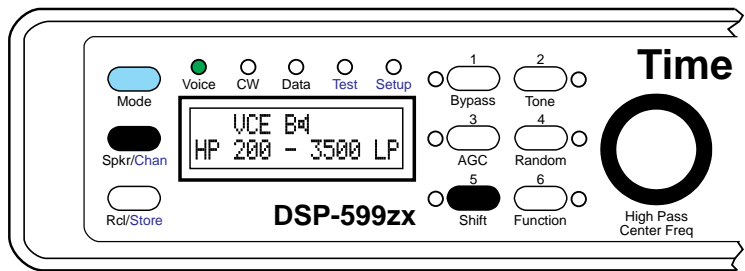

599-032

Pressing **[Shift+Chan]** toggles between channels A and B. The DSP-599zx audio gain control simultaneously controls volume level of both channels. **Setup** mode allows adjustment of the relative volume of the A channel with respect to the B channel.

Setup mode also allows you to configure the two output channels independently. It is possible to configure the Line Out for each channel differently from the external speaker and headphone outputs. This can be very convenient when working in one of the Data modes. The Line Out can then be connected to a multi-mode controller.

The DSP-599zx requires external speakers and/or headphones to hear the audio signal. The DSP-599zx will accept either stereo or mono headphones with a 1/4" plug. Stereo headphones are the preferred over monaural headphones so that you monitor both output channels simultaneously.

Visible Memories

The DSP-599zx has six memories to store complete settings and configurations. Pressing **[Shift+Store+{#}]** (# = 1-6) stores every setting and setup configuration except the audio gain control position. Pressing **[Rcl+{#}]** instantly recalls the complete settings and setup configuration stored in a memory and displays them on the LCD.

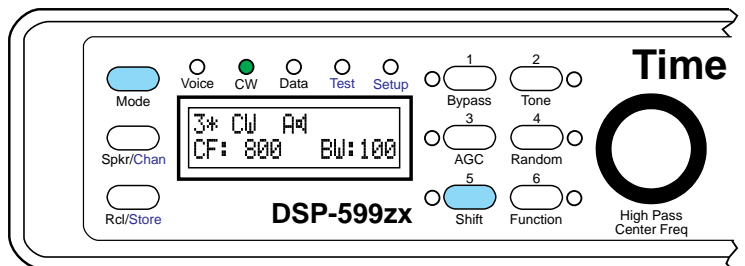

599-016

Automatic Gain Control

The DSP-599zx has switch-selectable automatic gain control to optimize the signal levels for best filter performance and to enhance listening by minimizing audible signal level variation.

Bypass Control

The DSP-599zx has bypass features that vary with the mode of operation. In voice and CW modes, the bypass setting routes the signal through relay contacts to completely bypass the electronic circuitry of the DSP-599zx. Turning the power off to DSP-599zx uses the same relay bypass method. In data mode, the bypass route is through the DSP processor. The amount of signal delay through the bypass route is equal to the delay through the processed signal route. The purpose of this delay equalization is to allow switching between signal processing and bypass without breaking the handshaking link of modes like Pactor and G-TOR.

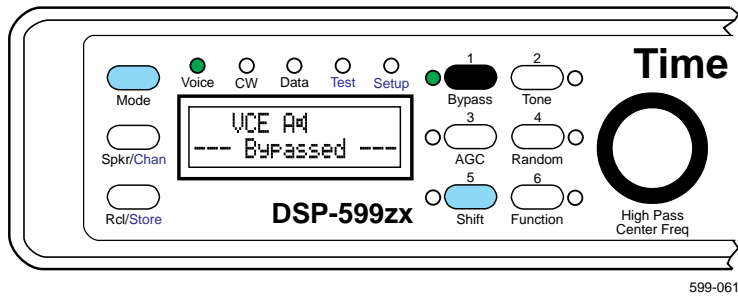

Bypass respects the status of the speaker switch. If the speaker is turned off, bypass leaves it off. The speaker will always, however, come on when power is turned off on the DSP-599zx.

Operating Modes

The DSP-599zx has three normal operating modes that operators will most often use:

- **Voice**
- **CW**
- **Data**

Pressing **[Mode]** steps from Voice mode to CW mode to Data mode back to Voice mode in a circular queue.

There are two more modes that operators will normally use during initial configuration, installation, and troubleshooting,

- **Set-up**
- **Test**

Pressing **[Shift+Mode]** once places the DSP-599zx in Test mode. Pressing **[Shift+Mode]** again steps to Setup mode. Pressing **[Mode]** at any time places the unit back in one of the normal operating modes again. When in a menu or test instrument mode, pressing the **middle knob** will back you up one level. Think of the **middle button** in most cases as a cancel/clear button.

Voice Mode

The Voice Mode digitally processes all analog voice signals for all modes including SSB, AM, FM, and PM. Independently selectable processing techniques include noise reduction, heterodyne elimination, tunable high-pass/lowpass filtering and automatic gain control.

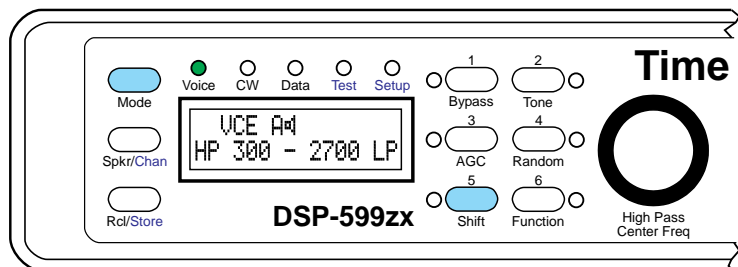

599-006

Highpass/Lowpass Filters

The DSP-599zx has highpass and lowpass filters that are independently tunable with front panel controls. The LCD display shows the corner frequencies of the filters as they are tuned. There are many uses for the variable combinations of highpass and lowpass filters that the DSP-599zx offers. In a typical example of a voice mode application, highpass and lowpass filters can improve a signal with a poor signal-to-noise ratio. The independent highpass and lowpass filters remove the low and high audio frequency components that do not contribute significantly to the speech intelligibility, thus improving signal quality. Another common voice mode example is the improvement of a SSB signal corrupted by adjacent channel interference (QRM). The steep skirts of the highpass and lowpass filters allow the operator to eliminate high side and low side interference independently with minimal impact on the desired signal.

The DSP-599zx highpass filter adjustment range is from 100 to 1000 Hz and the lowpass range is from 1000 to 5000 Hz. Although the DSP-599zx has bandpass filters for CW and the most common data modes, the selectable highpass and lowpass filter combinations also allow precise filtering for modes such as wideshift RTTY.

Random Noise Reduction

The DSP-599zx random noise reduction has proven to be useful in reducing a wide variety of noise types, including white noise, line noise and static crashes. The amount of noise reduction varies according to the characteristics of the noise. Typical noise reduction ranges from 5 dB to 20 dB. It is possible to change the level of aggressiveness within a regular operating mode without going into setup mode.

Adaptive Multi-tone and Manual Notch Filtering (Tone noise reduction)

The DSP-599zx has both an automatic notch filter and a manually tuned filter. The automatic multi-tone filter removes multiple heterodynes almost completely.

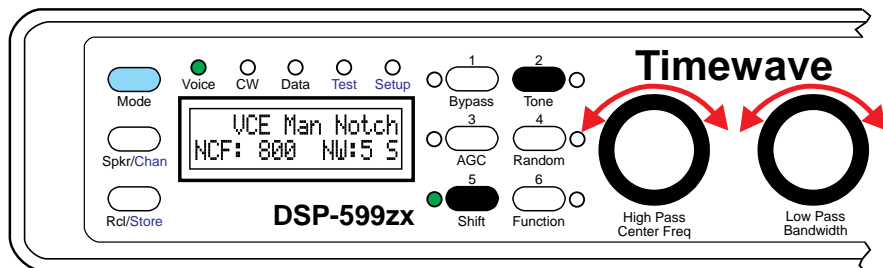

599-027

The manual notch filter is selectable for either a wide bandwidth for data signals and a narrow bandwidth for CW signals and heterodynes. The center frequency of the filter is easily set.

CW Mode

The CW Mode digitally processes analog CW (Continuous Wave) signals for Morse code reception. Independently selectable processing techniques include noise reduction, tunable bandpass filtering and automatic gain control.

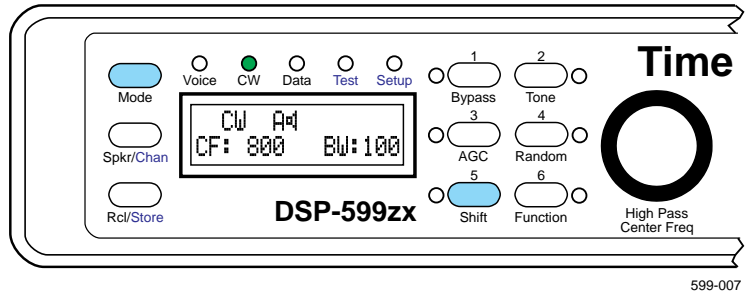

Bandpass Filters

The DSP-599zx has a fully tunable bandpass filter for use in the CW mode. The LCD display shows the center frequency and bandwidth of the filter as the operator tunes with front panel controls. Narrow band signals like CW and RTTY require a bandpass filter with steep skirts and linear phase response. Linear phase response maximizes the usable signaling rate for a given bandwidth and minimizes ringing often heard on other extremely sharp crystal and audio filters.

The DSP-599zx CW filter has skirts so steep that a signal literally falls off the edge of the passband as you tune through a CW signal. Bandwidths for the bandpass filter range from 10 Hz to 600 Hz, and center frequencies range from 200 to 1000 Hz. The narrow filter bandwidths are useful for trying to dig out extremely weak signals from the noise and QRM. The wider filter bandwidth allows easy tuning and listening to multiple CW signals simultaneously.

Random Noise Reduction

The DSP-599zx random noise reduction has proven to be useful in reducing a wide variety of noise types, including white noise, line noise and static crashes. The amount of noise reduction varies according to the characteristics of the noise. Typical noise reduction ranges from 5 dB to 20 dB. In the CW mode, random noise reduction is generally most effective in the wider CW bandwidths (400-600 Hz).

Manual Notch Filtering

The DSP-599zx has a manually tuned notch filter. The **[Center Freq]** encoder on the front panel tunes the manual notch filter. The manual notch filter has both a wide bandwidth choice for data signals and a narrow bandwidth choice for CW signals and heterodynes. Usually a narrow bandwidth filter is most effective for the greatest improvement of a CW signal, but some operating conditions (i.e., a contest) dictate a wide CW filter bandwidth. The manual notch can remove a single strong annoying signal.

Marker Tone

Pressing **[Tone]** while in the **CW** operating mode inserts an audio marker or spotting tone at the center frequency of the bandpass filter. Tuning the bandpass filter center frequency changes marker tone center frequency. Matching the marker tone frequency with the received signal allows switching in a narrow filter without losing the signal outside the passband of the narrow filter. The level of marker tone is adjustable relative to the processed receive signal.

CW Tone Pitch Shift

A feature unique to the DSP-599zx is the ability to easily shift the CW tone pitch to another frequency. This feature works well with receivers that have non-adjustable, relatively high pitch CW tone, since most hams prefer to listen to 400 - 600 Hz CW tones.

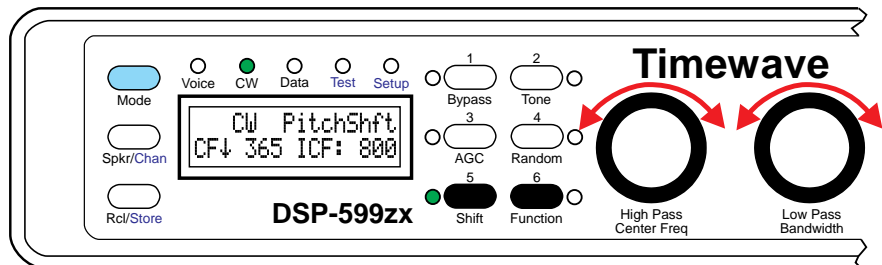

599-014

Data Mode

The Data Mode digitally processes data signals including RTTY, AMTOR, PacTOR, G-TOR, CLOVER HF packet, SSTV and WeFAX. Independently selectable processing techniques include noise reduction, tunable bandpass filtering and automatic gain control, and a special RTTY modem and RTTY remodulator.

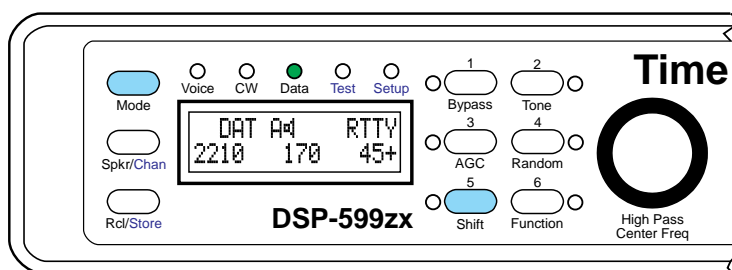

599-029

Bandpass Filters

The DSP-599zx has both fixed and tunable bandpass filters for the data mode. Narrow band FSK signals like RTTY require a bandpass filter with steep skirts, linear phase response, and matched amplitude response. Linear phase response maximizes the usable signaling rate for a given bandwidth and minimizes ringing often heard on extremely sharp filters. The matched amplitude response tailors the filter to match the selected modulation type and baud rate to minimize noise and interfering signals.

The DSP-599zx also has fixed frequency matched bandpass filters centered at 2210 Hz as well as lower frequencies for European standards and 1600-1800 Hz HF packet. The selectable bandwidths of the bandpass filters provide optimum filtering for 170 Hz and 200 Hz frequency shift data signals of various baud rates.

The DSP-599zx has individual linear phase fixed bandpass filters with steep skirts for SSTV, WeFAX and CLOVER. Since the bandwidths for these modes are fixed, the filters are primarily QRM filters for adjacent channel signals rather than noise reduction filters for eliminating random noise. The SSTV filter is a dual passband filter with one passband centered on the SSTV sync pulse at 1200 Hz, and the other passband around the varying FM picture tones from 1500-2300 Hz. WeFAX is similar to SSTV but has no separate sync pulse so the filter bandpass covers 1500-2300 Hz. The CLOVER filter has a 500 Hz bandwidth with a center frequency of 2250 Hz.

Data Tuning Function

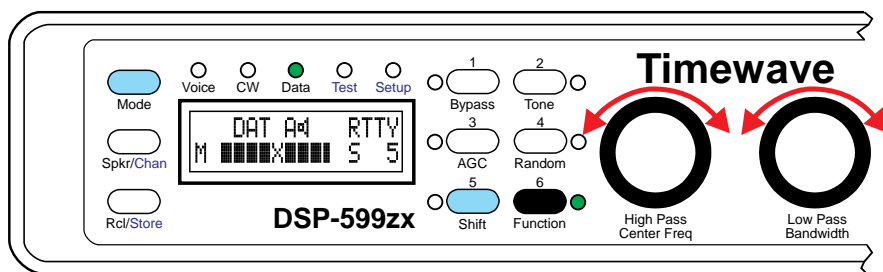

599-057

Pressing **[Shift+Function]** turns the tuning display on. This display provides information graphically to allow precise tuning of the receiver. The display also shows the strength of the incoming data signal.

Random Noise Reduction

The DSP-599zx random noise reduction function is not specifically designed for data signals, but has been field proven to be useful for noise reduction under some conditions. It is usually most effective for 45.5 baud RTTY signals.

RTTY Modem

The DB-9F connector provides an RS-232 compatible connection for the RTTY modem output to a computer. The output is demodulated FSK in the same code format (Baudot, ASCII, etc.) as the received signal. It is not decoded or changed in any way except for demodulation. The AFSK modulated output for the transmitter appears on the line output connector of the selected channel. The channel is selectable within setup. The PTT output signal needed to put your transceiver in transmit mode is part of the DIN connector for the appropriate channel.

The AFSK output is a modulated AFSK signal in the same code format (Baudot, ASCII, etc.) as the keying signal from the computer. The DSP-599zx does not encode or change the signal in any way except for AFSK modulation. A software terminal program that can decode and encode Baudot and ASCII code needs to be installed on the computer connected to the DSP-599zx. Timewave does not provide the terminal program. This modem is for RTTY operation only with signaling rates at 75 Baud or less.

This modem feature is designed for RTTY operation. It is not designed to be used as a TNC.

RTTY Remodulator

The DSP-599zx has another special data function for RTTY only. After passing through the optimized RTTY bandpass filter, a precision DSP-based FSK detector in the DSP-599zx demodulates the noisy incoming RTTY tones and uses the recovered digital data to drive a precision DSP-based AFSK generator. This remodulation process takes place entirely in the DSP-599zx. The precise clean tones from the RTTY AFSK remodulator can feed any analog multimode controller or TU via the DSP-599zx line audio output.

Many analog RTTY demodulators have difficulty with noisy signals of varying amplitude, but virtually all of them can adequately demodulate the precise DSP AFSK generator output. The **[Function]** push-button selects either the remodulator with RTTY filters or the RTTY filters only. This remodulator is optimized for non-burst data at 75 Baud or less.

RTTY FSK Test Signals

Press **[Tone]** while in the non burst Data mode at 75 baud or less activates a sync nul (diddle) test tone. If the baud rate is 100 baud or higher, pressing **[Tone]** activates a space mark reference calibration tone.

Pressing **[Shift+Tone]** while in the **Data** RTTY mode at 75 baud or less inserts an audio FSK test signal into the receive channel. The “RYRY” test signal is centered at 2210 Hz with a frequency shift of +/- 85 Hz. The baud rate is determined by the RTTY parameter settings. The level of marker tone is adjustable relative to the processed receive signal. If the baud rate is 100 baud or higher, nothing happens when **[Shift+Tone]** is pressed.

Test Instrument Mode

The Test Instrument function helps analyze signals and other equipment. It includes an audio millivoltmeter, an audio signal generator, and an audio tone decoder.

Audio Millivoltmeter

This mode measures audio voltage levels from other equipment including microphones, TNCs, multimode controllers, and receivers. Measurements are both peak and true RMS millivolts. Frequency response ranges from 20 Hz to 10 kHz. In EME work, the audio millivoltmeter mode is useful in antenna evaluation when comparing sun noise and cold sky noise.

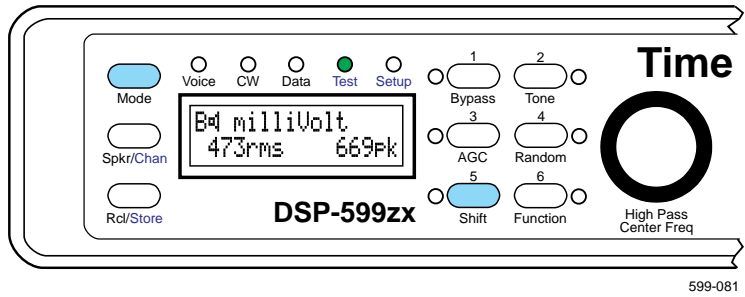

Maximum input level is 2000 millivolts rms.

Do not attempt to measure any voltage above 2000 millivolts, especially 115 Vac or 220 Vac power line voltage! You will damage the DSP-599zx! ALL WARRANTIES WILL BE VOID!

Audio Signal Generator

This mode produces tunable low-distortion, precision frequency sine wave test signals from 20 Hz to 10 kHz in 10 Hz steps. A two-tone test signal may be selected for SSB testing. The operator may use the precision test signals for calibration and/or trouble shooting of other equipment the user may own. The display shows the frequency and amplitude of the output signal from the line output.

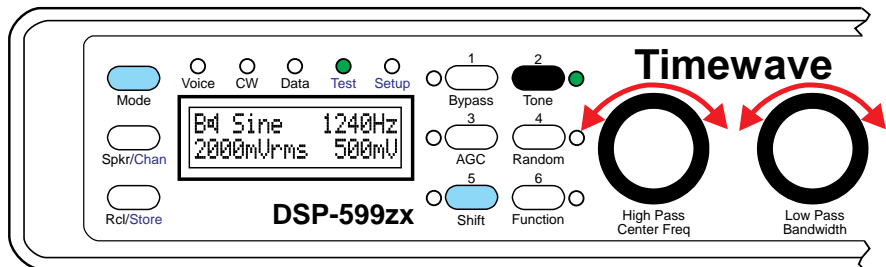

Two-Tone Generator

Produces a two-tone signal that can be used for SSB linearity testing. The DSP-599zx produces a very pure tone set. This provides for very accurate testing.

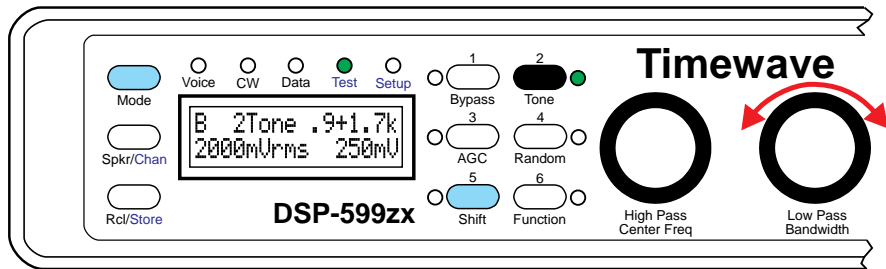

599-047

CTCSS Tone Decoder

This mode decodes CTCSS tones. The CTCSS function shows the tone frequency and amplitude on the LCD display. There are two modes of operation. The first is the autodetect mode which displays the frequency and amplitude of any valid CTCSS tone received. The second is the tone squelch mode which detects a selected CTCSS tone and activates a switch output on the DSP-599zx as well as generates a tone on the selected CTCSS frequency. The audio millivoltmeter function displays the peak amplitude of the selected incoming CTCSS tone. This allows relative measurement of peak deviation of CTCSS tones and voice for UHF and VHF FM/PM transmitters.

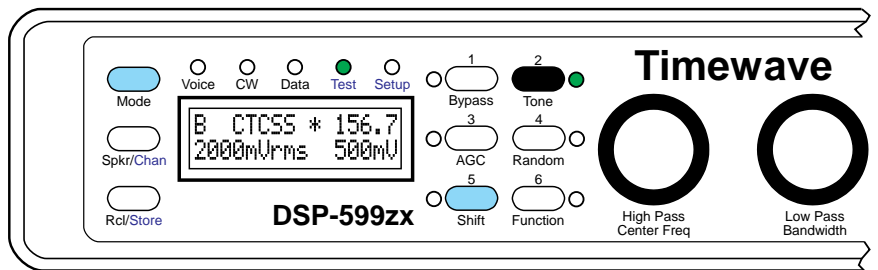

599-054

DSP-599zx Specifications

AUDIO INPUT A & B

Impedance	20 K ohms or 25 ohms, jumper selectable
input signal range for full output	10 mV to 1.0 volt, front panel programmable

AUDIO OUTPUT A & B

Speaker output power	1.0 watts into 8 ohms at 13.8 VDC, both output channels A & B operating, 1.5 watts into 4 ohms at 13.8 VDC, both output channels A & B operating,
Line Output	-3 dBV to -24 dBV referenced to input level. Adjustable within setup.
Headphone Jack	1/4" two-circuit jack, use stereo headphones to use all functions, mono headphones for most functions
Harmonic Distortion	less than 1% at rated output

NOISE REDUCTION FILTERS

	Frequency Range	Attenuation	Type	Delay
Random Noise Reduction	entire freq. range of selected filter	Up to 20 dB, varies with noise characteristics. Noise reduction aggressiveness front panel adjustable	Adaptive	5 msec max
Heterodyne Eliminator (multiple automatic notch)	entire freq. range of selected bandpass filter	Up to 50 dB, varies with noise characteristics	Adaptive	5 msec max
Heterodyne Eliminator (manual notch)	entire freq. range of selected bandpass filter	Up to 50 dB, varies with noise characteristics	manual	
Note:	The random noise reduction and bandpass filters can operate simultaneously. The random noise reduction, tone notch and highpass/lowpass filters can operate simultaneously.			

CW FILTERS

CW filters	Bandwidth = 5 Hz to 600 Hz, 10 Hz steps. Center freq. = 200 to 2150 Hz, 5 Hz steps,	55 dB at 60 Hz outside the passband	FIR Linear phase	BW less than 20 Hz=64 msec max BW greater 20 Hz=40 msec max
CW Marker Tone	Sine wave at center freq. of selected CW filter.			

DATA FILTERS

RTTY, AMTOR, PACTOR, G-TOR, HF Packet	Mark/Space bandwidth 60 Hz to 100 Hz, Center Freq.= 2210 Hz plus options of 1700, 1360, 1300, 1530 or 2125 Hz	40 dB at 60 Hz outside the passband	FIR Linear phase	38 msec max
Note:	RTTY and AMTOR filters have a notch at the center frequency .			
CLOVER	2000-2500 Hz	55 dB at 75 Hz outside the passband	FIR Linear phase	21 msec max
SSTV	1100-1300 Hz & 1500-2300 Hz	50 dB at 75 Hz outside the passband	Composite FIR Linear phase	21 msec max
WeFAX	1500-2300 Hz	55 dB at 75 Hz outside the passband	FIR Linear phase	21 msec max
FSK Marker Tones	1) RY string - Alternating sine waves at mark-space freq. of selected data filter (170 or 200 Hz shift). Baud rate matches selected RTTY data mode. 2) Sync-Nul Character (Diddle) - Baud rate matches selected data filter.			

RTTY MODEM

Shifts	170, 200, 425, 850 Hz
Data Rates	45, 50, 57, 75 Baud
Input	Audio from receiver.
Output	Open collector FSK and variable level AFSK
Transmit Data Polarity	Normal or Reverse
I/O	Receive data, Transmit data, PTT (RS-232 compatible)

VOICE FILTERS

	Frequency Range	Attenuation	Type	Delay
Highpass	Corner freq. = 100 to 1000 Hz, 10 Hz steps.	60 dB at 180 Hz outside the passband	FIR Linear phase	24 msec max for any combination of
Lowpass	Corner Freq. = 1000 to 5000 Hz, 10 Hz steps.	60 dB. at 180 Hz outside the passband	FIR Linear phase	highpass & lowpass

AGC

Voice mode	36 dB
CW and Data Modes	18 dB

SIGNAL PROCESSING

A-D/D-A Converter	16 bit linear, sigma-delta conversion, dual channel
Signal Processor	16 bit, 27 ns Analog Devices ADSP-2181 with 80 KB of memory

TEST INSTRUMENT MODE

Audio Generator	Single or two-tone. single Sine wave tunable from 20 Hz to 10 kHz. Two-tone fixed 700 Hz and 1900 Hz. Sine wave distortion less than 1%.
Audio milli-voltmeter	True RMS from 4 mV to 2000 mV., 20 Hz to 10 kHz
CTCSS encoder - decoder	Generates and decodes and displays CTCSS "PL" tones from 67.0 Hz to 254.1 Hz.
CTCSS squelch	Open collector output pulls low when selected CTCSS tone is present. (connection on back panel DIN connector)

MEMORY

Six Memories	All configuration setups can be stored and recalled (except volume control setting).
--------------	--

DISPLAY

2x16 alphanumeric characters, dot-matrix, yellow-green backlit LCD.

DIMENSIONS

Size	7.6 in. wide x 8.5 in. deep x 1.9 in. high (193 mm wide x 216 mm deep x 48 mm high)
Weight	2.53 lb. (1.15 Kg.)

POWER

Requirements	12-16 VDC @ 1A
Fuse	1.6A 5 mm x 20 mm

Note: RTTY, AMTOR, PacTOR, G-TOR and HF Packet data filter bandwidths are specified at -3 dB points to comply with traditional data filter specification methods. All other filter bandwidths are specified to comply with conventional DSP FIR filter parametric descriptions.